

විස්තීර්ණ පළාත් අධ්‍යාපන දෙපාර්තමේන්තුව - කොළඹ අධ්‍යාපන කලාපය කලාපීය විස්තීර්ණ පළාත් மேல் மாகாணக் கல்வித் திணைக்களம் - கொழும்பு கல்வி வலயம் மேல் மாகாணக் கல்வித் திணைக்களம் - கொழும்பு கல்வி வலயம் Western Provincial Education Department - Colombo Educational Zone Western Provincial Education Department - Colombo Educational Zone	කොළඹ අධ්‍යාපන කලාපය විස්තීර්ණ පළාත් අධ්‍යාපන දෙපාර්තමේන්තුව - කොළඹ අධ්‍යාපන කලාපය කලාපීය විස්තීර්ණ පළාත් மேல் மாகாணக் கல்வித் திணைக்களம் - கொழும்பு கல்வி வலயம் மேல் மாகாணக் கல்வித் திணைக்களம் - கொழும்பு கல்வி வலயம் Western Provincial Education Department - Colombo Educational Zone Western Provincial Education Department - Colombo Educational Zone
இரண்டாம் தவணை மதிப்பீடு : 2016 Second Term Evaluation - 2016	
7 ශ්‍රේණිය தரம் 7 Grade 7	கணிதம் வினாத்தாள் Mathematics Paper I
පැය දෙකයි ஒரு மணித்தியாலம் Two Hour	

Name :- ..... Index No :- .....

Part - I

- Answer all questions.
- Each question carries two marks.

01)

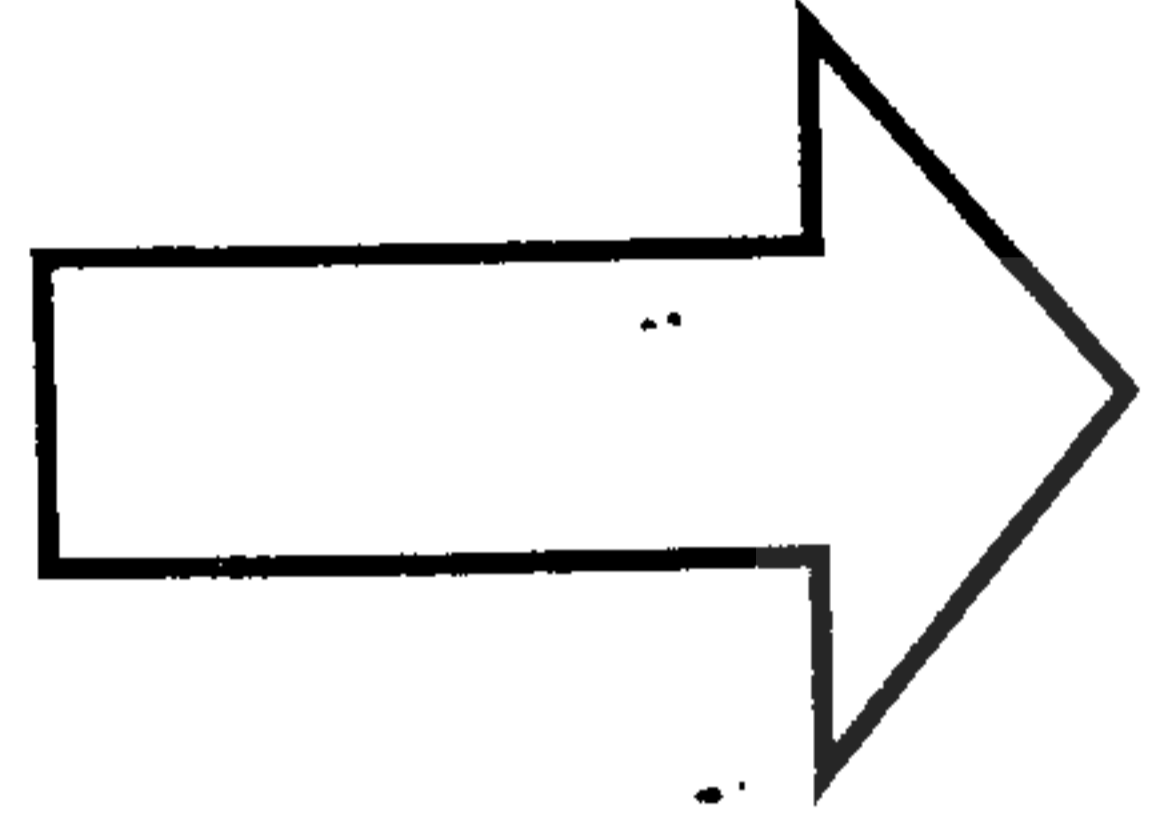

How many symmetrical axes are there in the following figure.

02) Capacity of a table spoon is 5ml. It is decided to give two table spoons three times per day. What is the amount of medicine needed?

03) Write in index form,

3 x 3 x a x 3 x 3

04) An example for a static angle which the arms are not static is an,

- (a) Angle between the edges of a cover of a book.
- (b) Angle between the sporks of a bicycle.
- (c) Angle between the hour hand and minute band.

05) If the number 25□8 is divisible by six, write down two suitable digits for the tenth place.

06) Simplify.

Years	Months	Days
8	5	12
- 2	10	24
<hr/>		
<hr/>		
<hr/>		

07) Write down the algebraic term and the coefficient of the algebraic expression.

$$6x - 3$$

algebraic term : .....

coefficient of the algebraic term : .....

08) Simplify.

g	mg
4	25
	$\times 6$
<hr/>	
<hr/>	
<hr/>	

09) Give  $\frac{22}{5}$  as a mixed number

10) My fathers' age is 4 times as my age. Now my age is  $x$ . Build up an algebraic expression for the age of my father 8 years ago.

---

11) Name the following triangle.

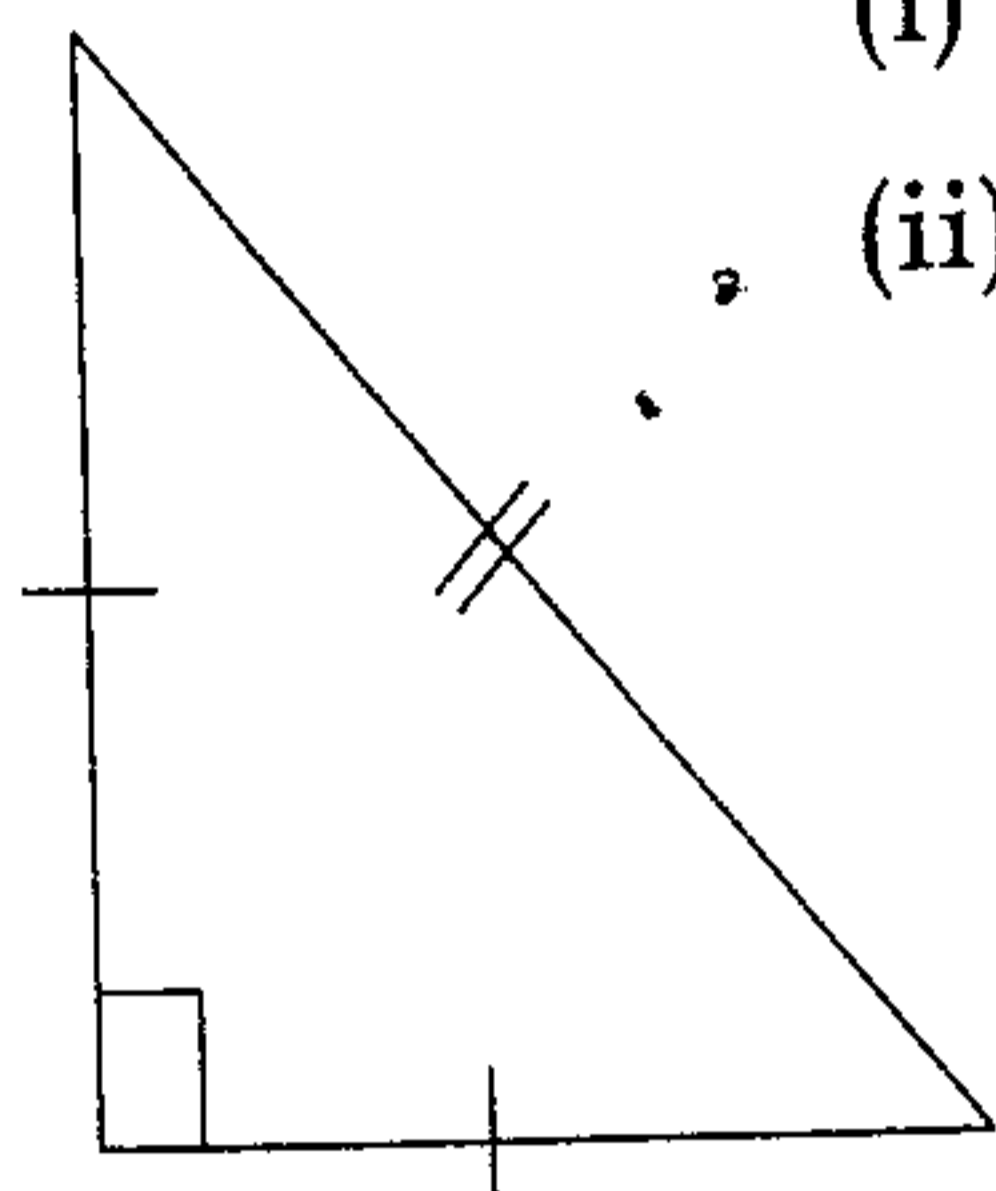

(i) according to sides .....

(ii) according to angles .....

---

12) A piece of length 1 m 25cm is cut off from a rope with the length of 50m. Find out the length of the remaining piece of the rope.

---

13) Simplify.  $4a - 5 = 7$

---

14)

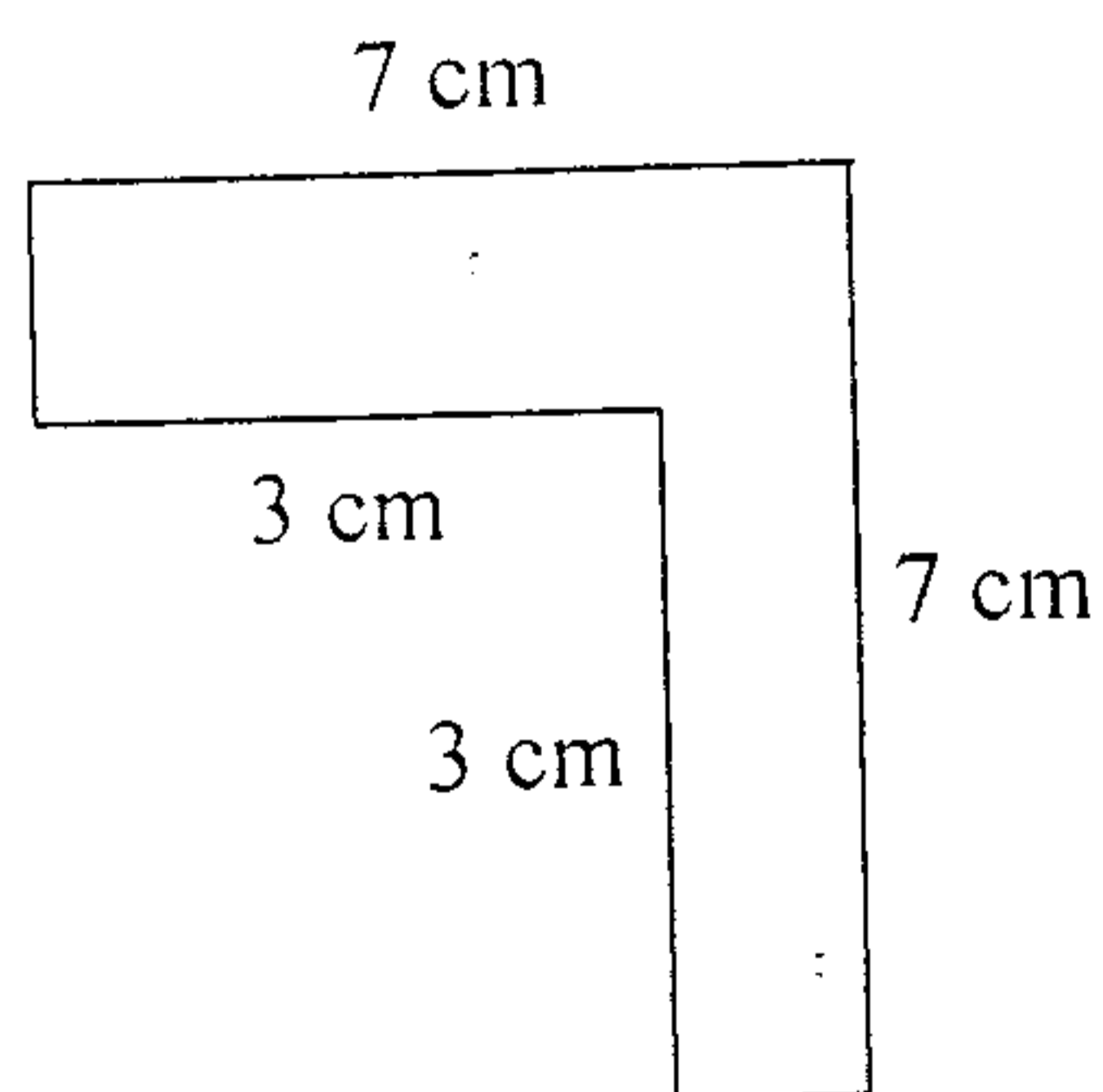

Find the area of the figure.

- 
- 15) Birthday of a person is 1900.06.02
- (i) Which century his birthday belongs?
  - (ii) Is it a leap year?
- 

- 16) Find the value.
- (i)  $2.48 \times 6$
  - (ii)  $37.3 \div 10$
- 

- 17) 2.25 l of water and 750 ml of fruit juice was mixed to prepare a soft drink. What is the amount of one glass if the soft drink is divided into 15 glasses equally in millilitres?
- 

- 18) Is a rhombus a regular polygon? Give reasons.
- 

- 19) What is the smallest number which is divisible by 15, 18 and 24.
- 

- 20) According to the given figures.

How many such small boxes can be packed inside the large box. (maximum number of boxes)

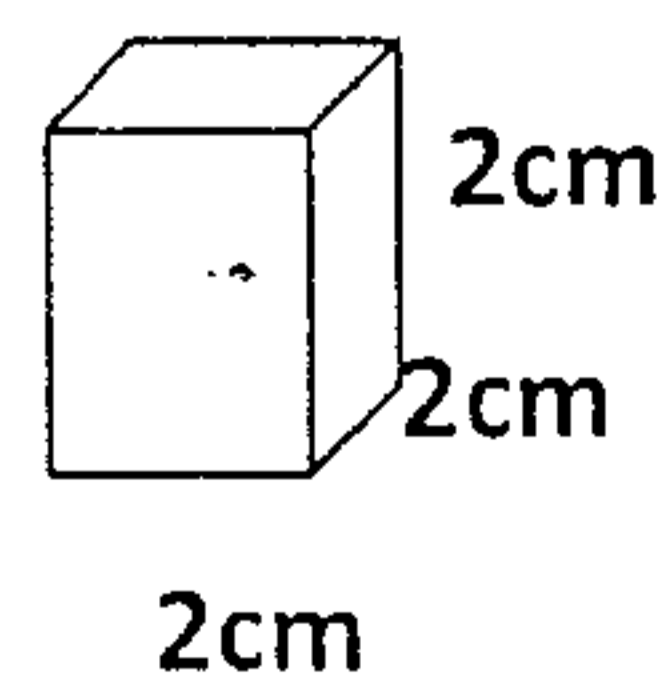
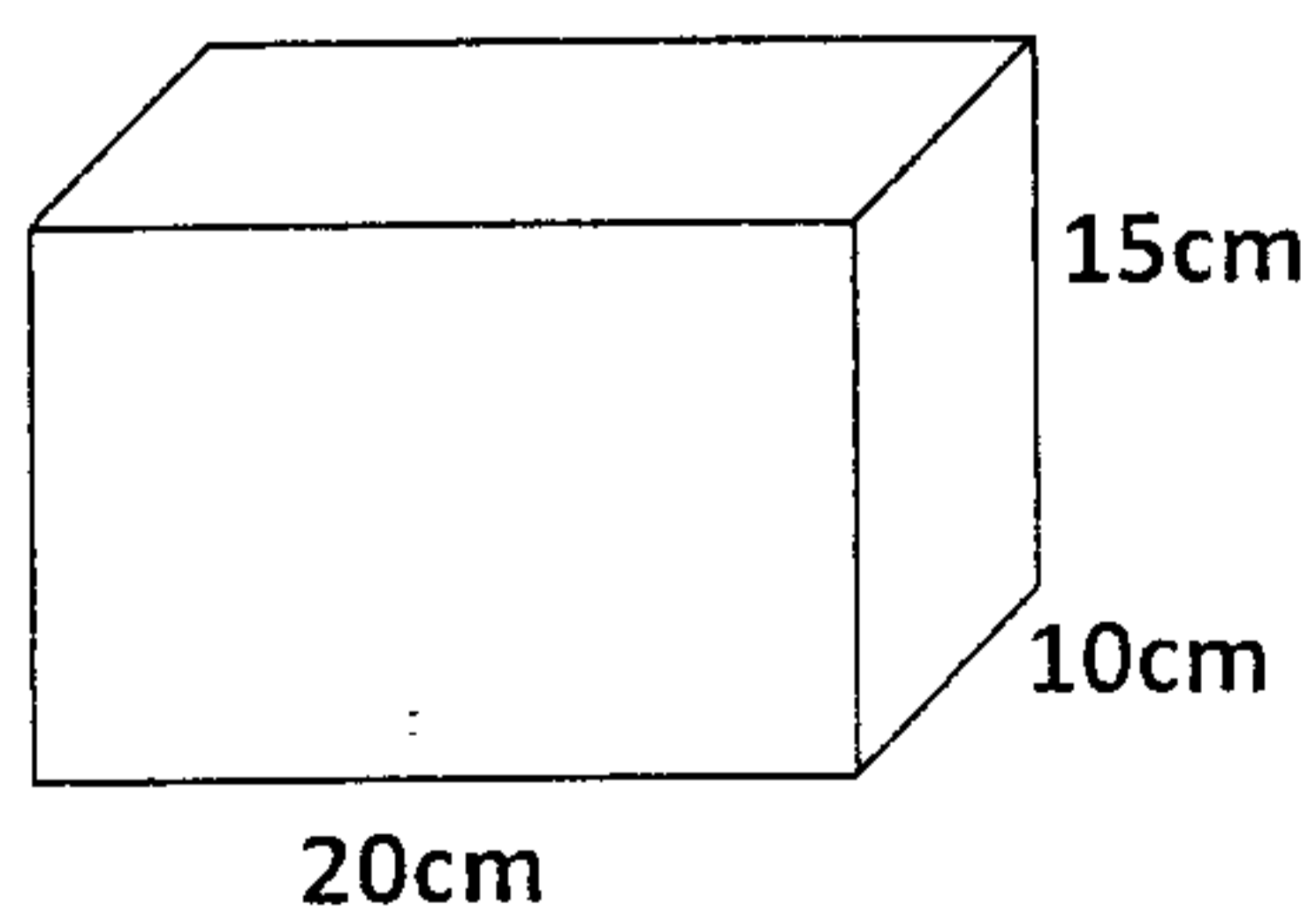

Part - II

- Answer question number one and four others.  
(16 marks for question (1) and 11 marks for the each of the other questions.)

- 01) (i) Recall the lesson about the rectilinear plane figures. What is the type of the assessment given by your mathematics teacher regarding the above lesson? (1 mark)
- (ii) List out occasions where you can see the following parallel lines in the environment.
- Horizontal parallel lines
  - Vertical parallel lines
  - Slant parallel line

(iii) According to the figure drawn above, name,

- A pair of horizontal parallel lines
- A pair of vertical parallel lines
- A pair of slant parallel lines
- A parallelogram
- A trapezium

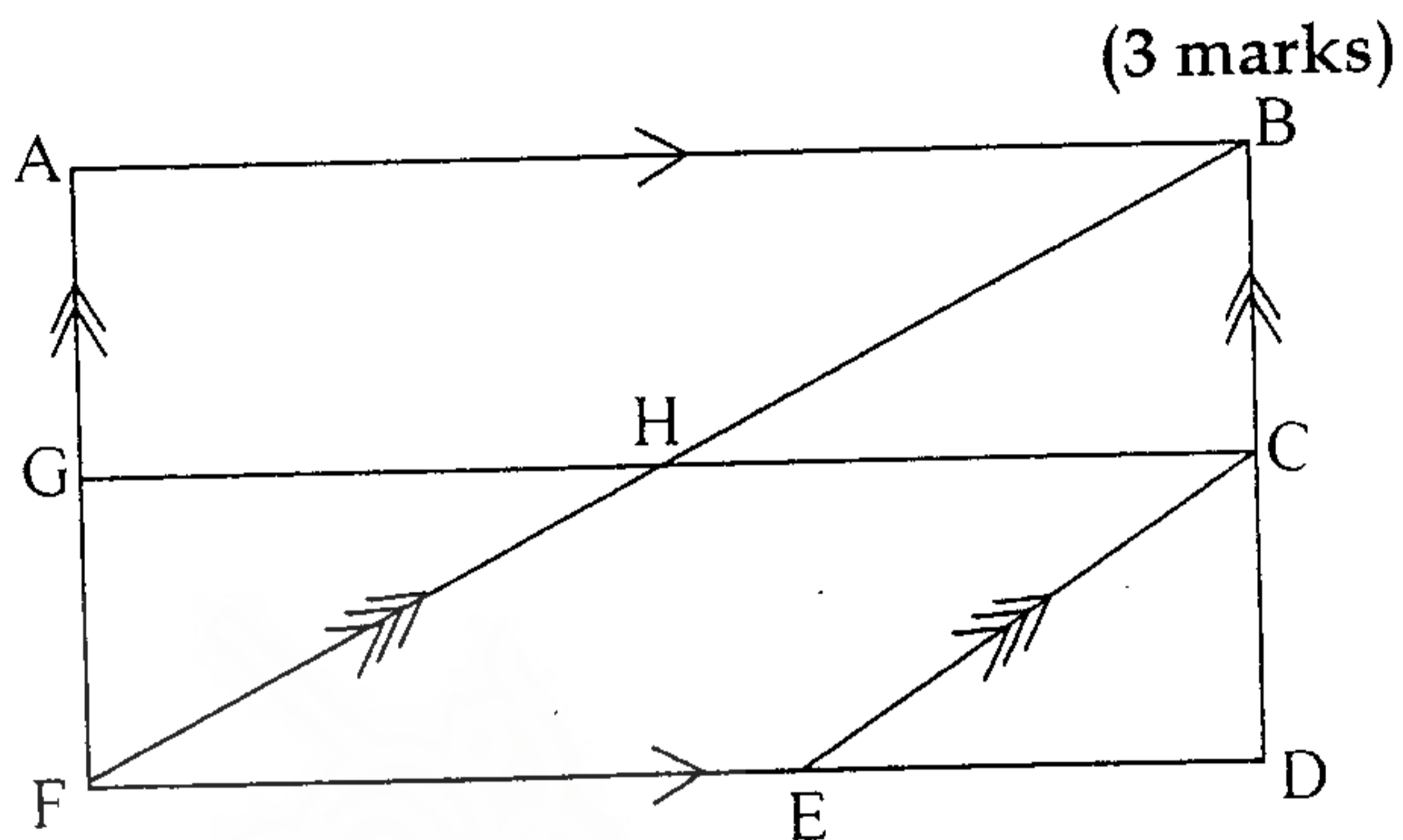

(3 marks)

(5 marks)

(iv)

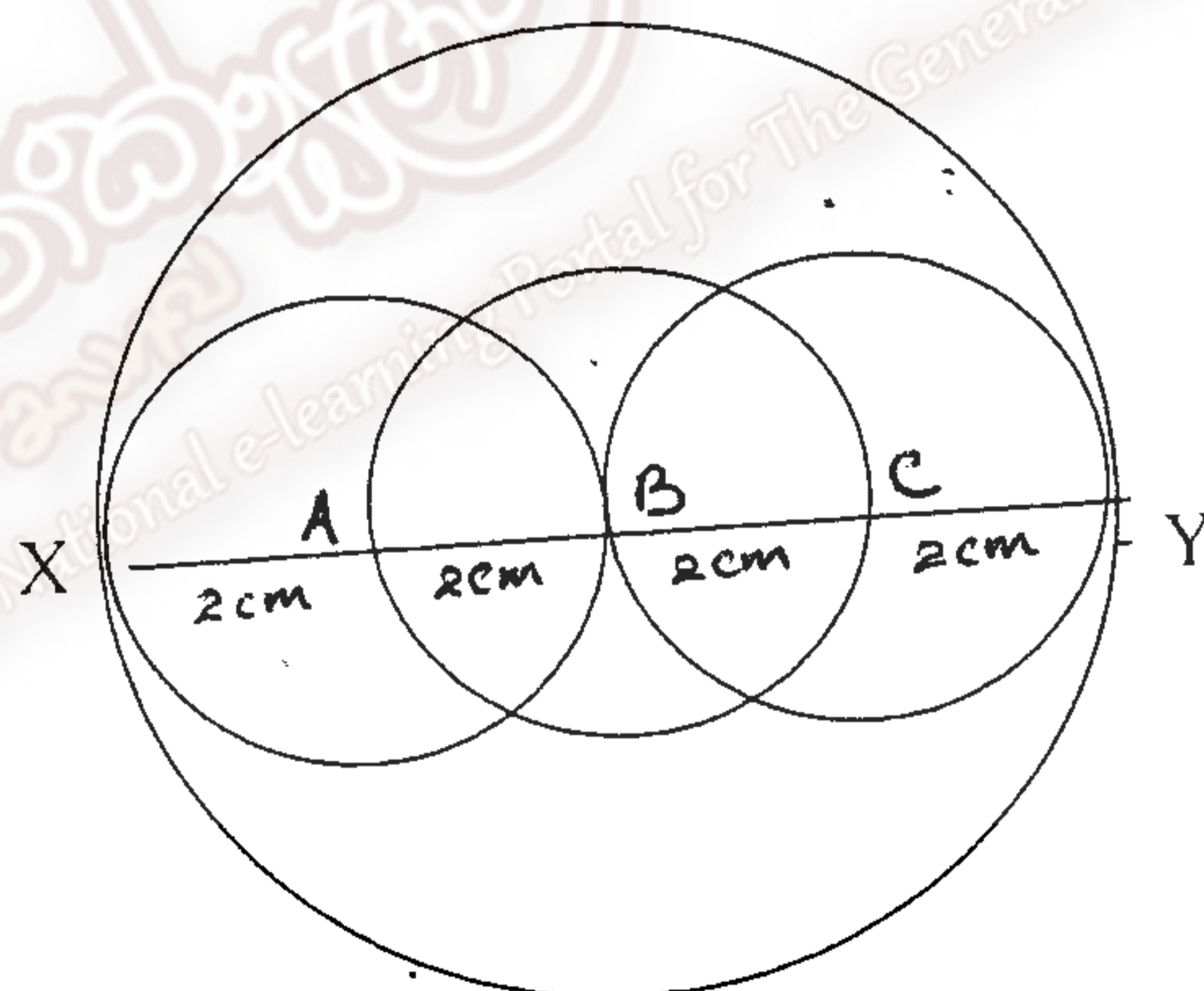

- How many circles are there in the above figure? (1 mark)
- What is the centre of the circle with the diameter AC? (1 mark)
- What is the radius of the circle with the centre A. (1 mark)
- What is the diameter of the circle with the radius C. (1 mark)
- Complete the blanks.
 

AB	radius	=	.....	radius	(1 mark)
XB	diameter	=	.....	diameter	(1 mark)
AC	diameter	=	.....	radius + .....	radius (1 mark)

02) (i) "Multiply  $x$  by 2 and subtract three". Build an algebraic expression for the above statement. (1 mark)

(ii) Give the algebraic expression  $\frac{a}{4} + 1$  in words (2 marks)

(iii) Simplify.

(a)  $2a - a + 8 - 6$

(b)  $4x + 5y - 3 - 2x - 2y$

(2 x 2 = 4 marks)

(iv) If  $x = 5$ ,  $y = 2$ , find the value

(a)  $2x - 3y - 3$

(b)  $2y + 3x - 8$

(2 x 2 = 4 marks)

03) (i) Build up a numerical expression for the following "Add three to five and multiply the answer by two" (1 mark)

(ii) Nadun says, the answer is five for the question.

$$21 - 6 \div 3$$

Show that his answer is incorrect and explain the mistake he made while obtaining the answer. (2 marks)

(iii) Simplify.

(a)  $20 \div 4 - 1$

(b)  $25 + 5 \times 4 \div 2$

(c)  $5(6 + 2) - 5$

(d)  $45 \div 3 - 3 \times 4$

(2 x 2 = 4 marks)

04) (i)

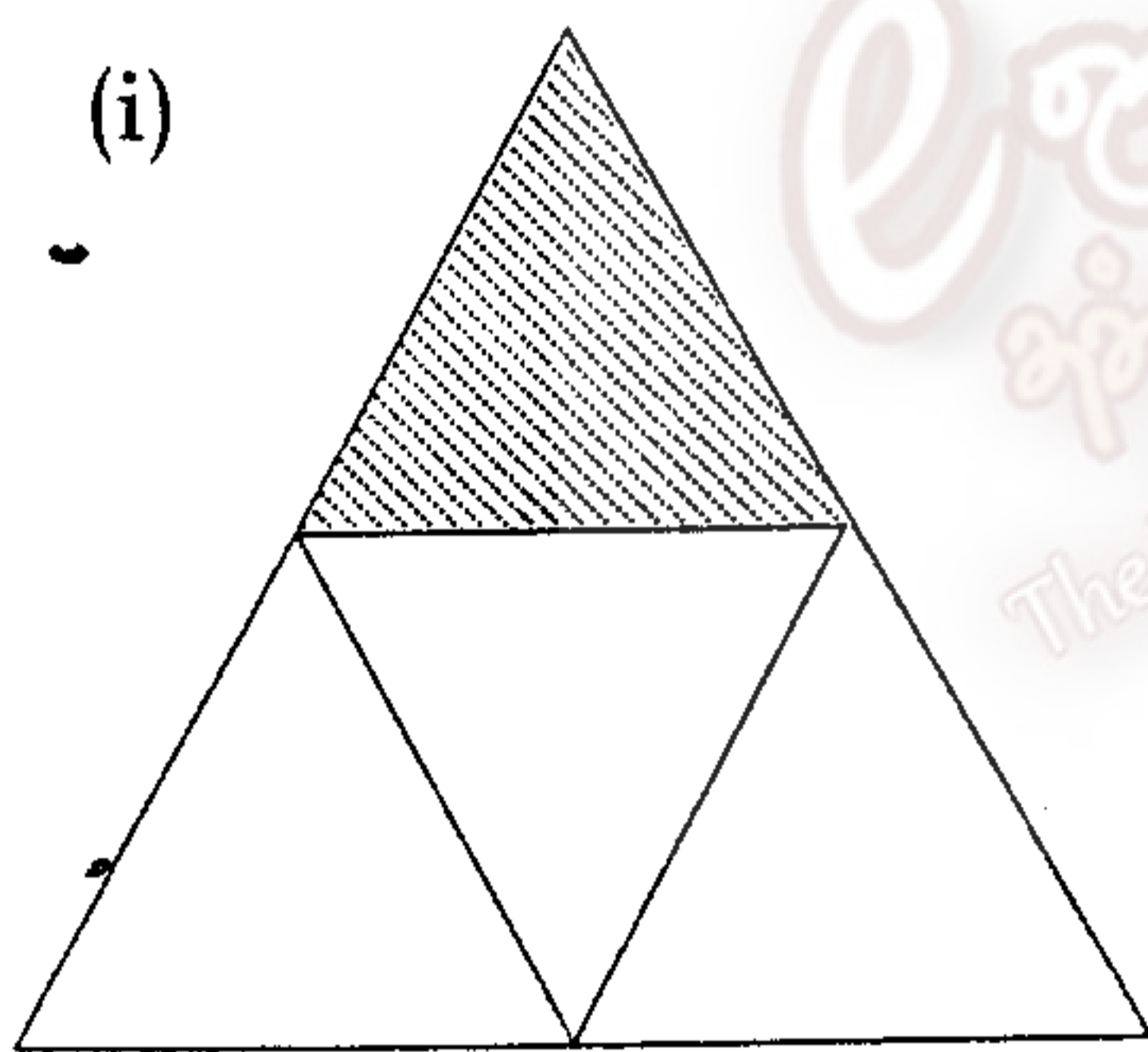

The area of the shaded part is  $8 \text{ cm}^2$ . Find the area of the figure approximately. (2 marks)

(ii) (a) Find the area of a rectangle where length 20cm breadth 50cm? (1 mark)

(b) Find the length of a side of a square with the same area as the above rectangle. (2 marks)

(iii)

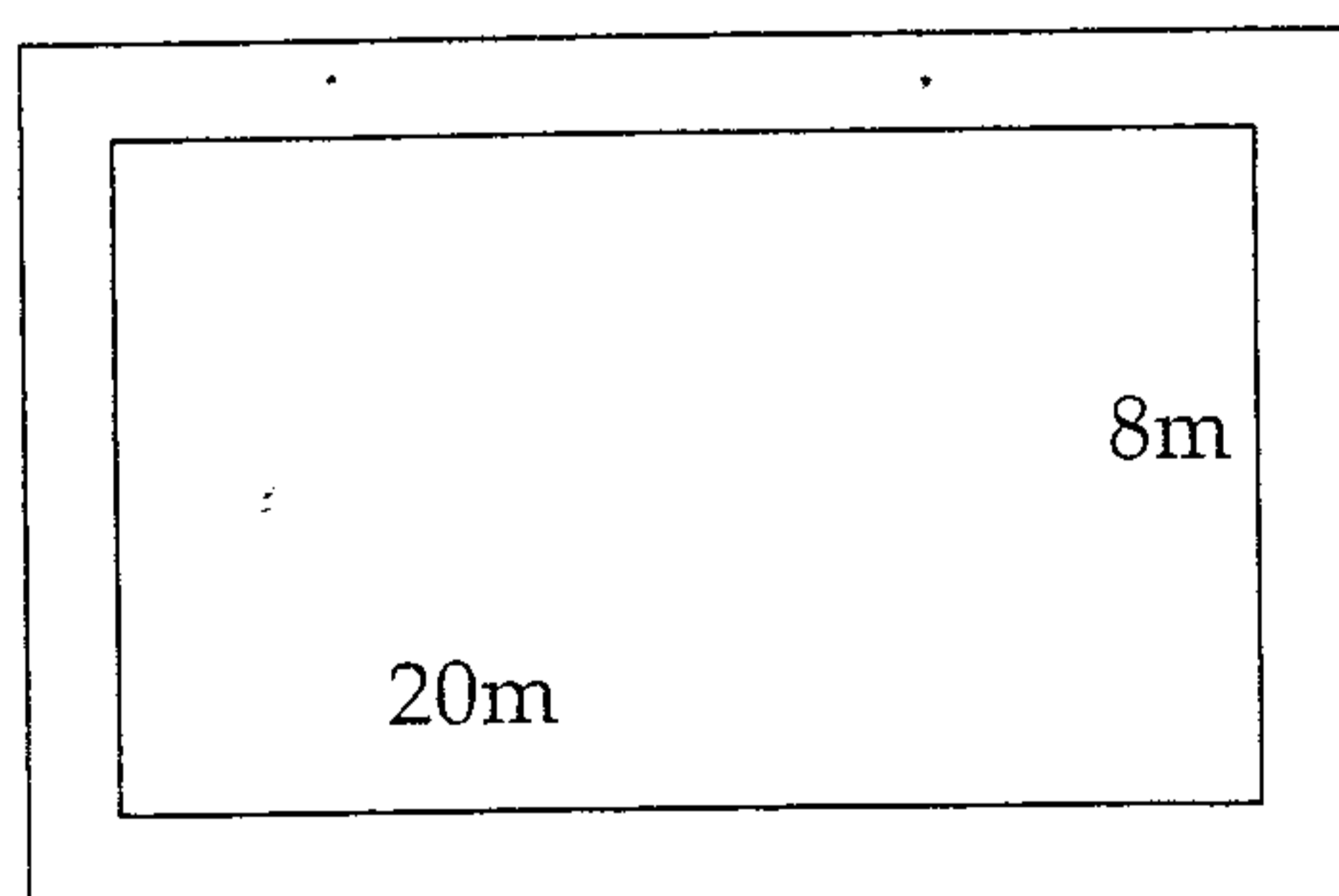

There is a road of 2m breadth around a rectangular land. The length and the breadth of the land is 20m and 8m respectively.

(a) Find the length and breadth of the land with the road. (2 marks)

(b) Find the area of the land with the road. (2 marks)

(c) Find the area of the road. (2 marks)

- (05) Construct the following using mathematical instrument.
- (i) Draw a line segment AB of length 8cm. (1 mark)
  - (ii) Draw the angle  $\hat{A}BC = 120^\circ$  (2 marks)
  - (iii) Mark point C such that BC = 6.5 cm and complete triangle ABC. (2 marks)
  - (iv) Draw a line through C vertex parallel to BA, using the ruler and the set square. (2 marks)
  - (v) Mark the point D on the parallel line 8cm away from the vertex C.  
(D Situated on the same side of vertex A) (2 marks)
  - (vi) Join A and D and measure and write the length of AD. (1 mark)
  - (vii) What is the name of the figure obtained? (1 mark)

- (06) (i) A = {Prime numbers between 0 and 10}
- (a) Represent the above set using the other two methods. (2 marks)
  - (b) "2 is an element of set A". Is this true? (1 mark)
- (ii) Write down the elements of the following sets as a list.
- (a) P = {Letters of the word "MAHARAGAMA"} (2 marks)
  - (b) X = {even numbers} (2 marks)
- (iii) T = {6, 12, 18, 24} (2 x 2 = 4 marks)

Write the set T in the description form.

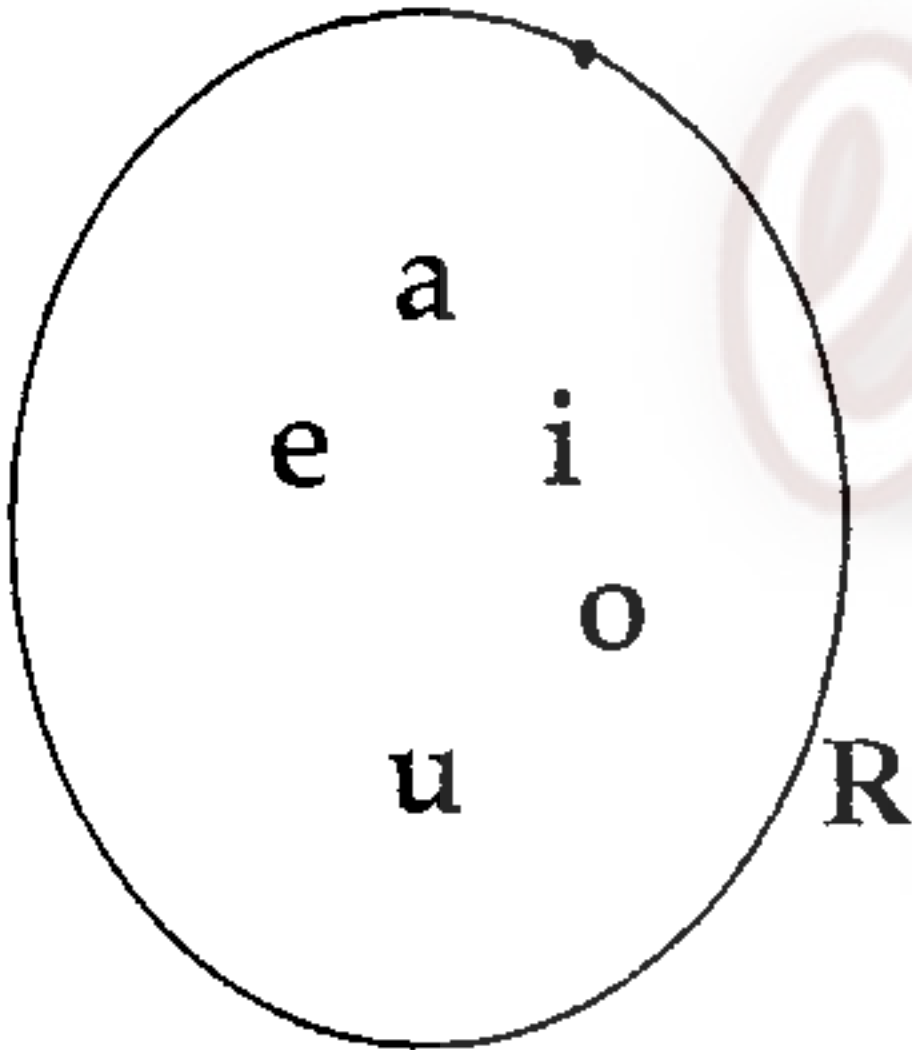
- (iv)  (a) Write the elements of the set R as a list. (2 marks)
- (b) Suggest a suitable name for set R. (1 mark)

- 07) (i) Find the value of  $(-6) + (+5)$  using the number line. (2 marks)
- (ii) (a) Write all the possible ways that you can write 48 as a product of two factors. (2 marks)
- (b) Find all the factors of 48 using the above result. (1 mark)
- (iii) Find the highest common factor of 30, 24, 18 (2 marks)
- (iv) Simplify.
- (a)  $2\frac{1}{5} + 1\frac{1}{3}$  (2 marks)
- (b)  $5\frac{5}{6} - 2\frac{1}{4}$  (2 marks)

\*\*\*\*\*